

QualityPlastics

570 Fifth Street
 Prescott, Az. 86301
 928-445-2592 Fax:928-445-1518
 WWW.QUALITY-PLASTICS.COM

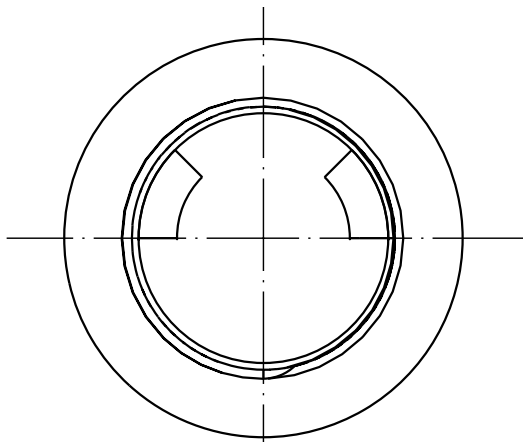

NECK DETAIL

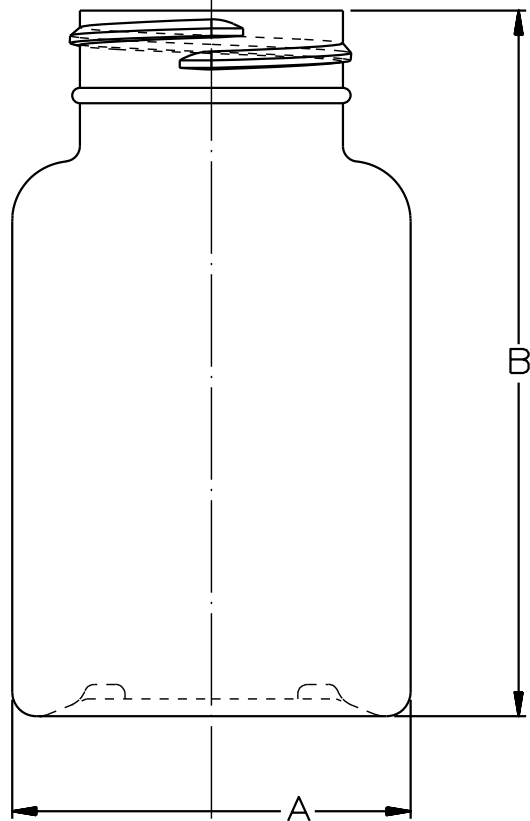
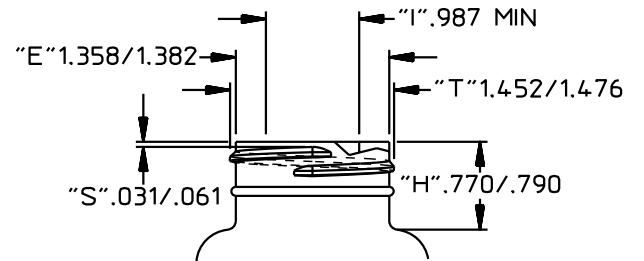

150cc Packer 38MM SPECIAL Drawing# 93-679-D

O.F.C.	161.4±6cc
WEIGHT	14.5g**
FINISH	38MM SPL
DIAMETER(A)	2.075±.062
HEIGHT(B)	3.675±.047
MAX LABEL(HEIGHT)	2.225
MAX LABEL(WIDTH)	N/A
PLUG FIT	USER SPECIFIED

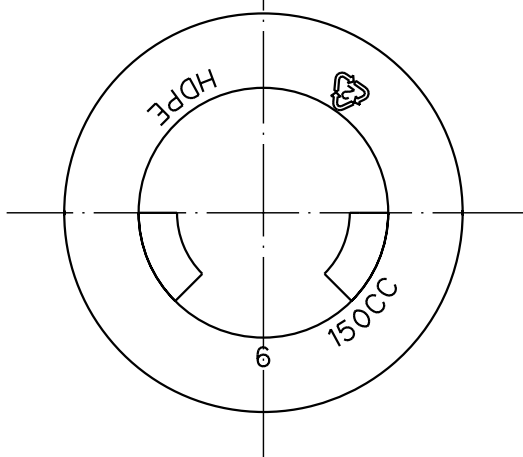

SPECIAL WEIGHTS AVAILABLE UPON REQUEST

MANUFACTURED BY EXTRUSION BLOW MOLD
 DRAWING NOT TO SCALE